

ECD – EXPANDABLE CORPECTOMY DEVICE

Continuously Expandable Vertebral
Body Replacement for Tumour Cases

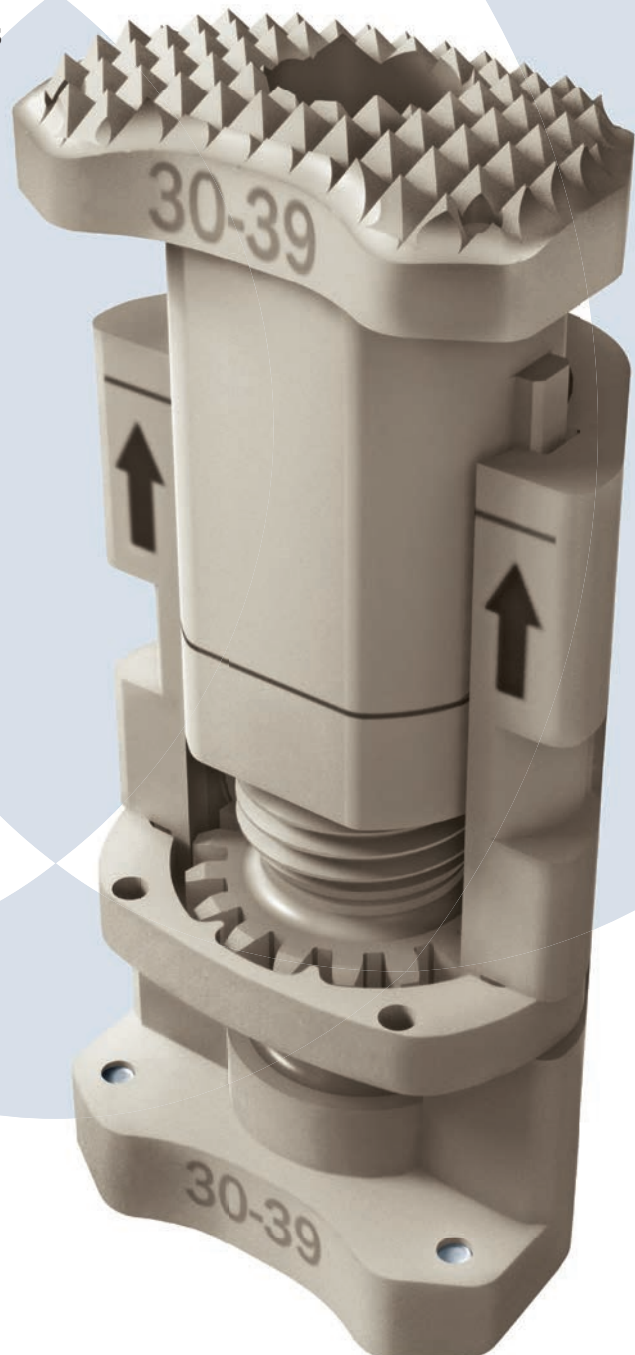

Instruments and implants approved by the AO Foundation.
This publication is not intended for distribution in the USA.

SURGICAL TECHNIQUE

 Image intensifier control

Warning

This description alone does not provide sufficient background for direct use of DePuy Synthes products. Instruction by a surgeon experienced in handling these products is highly recommended.

Processing, Reprocessing, Care and Maintenance

For general guidelines, function control and dismantling of multi-part instruments, please contact your local sales representative or refer to: <http://emea.depuyshes.com/hcp/reprocessing-care-maintenance>
For general information about reprocessing, care and maintenance of Synthes reusable devices, instrument trays and cases, please consult the Important Information leaflet (SE_023827) or refer to: <http://emea.depuyshes.com/hcp/reprocessing-care-maintenance>

TABLE OF CONTENTS

INTRODUCTION	ECD – Expandable Corpectomy Device	2
	AO ASIF Principles	4
	Indications and Contraindications	5

PRODUCT INFORMATION	Implants/Set	6
	Instruments	7

SURGICAL TECHNIQUE	Preoperative Planning	8
	Patient Positioning and Approach	9
	Surgical Technique	10

ECD – EXPANDABLE CORPECTOMY DEVICE

ECD is a vertebral body replacement for the cervical and upper thoracic spine. Its expansion mechanism allows smooth, continuous expansion in situ. Radiolucent PEEK implants with different heights and endplate angulations enable the surgeon to choose the specific configuration suited to the individual pathology and anatomical condition.

Fast surgical procedure
Only one instrument for holding and expanding the implant

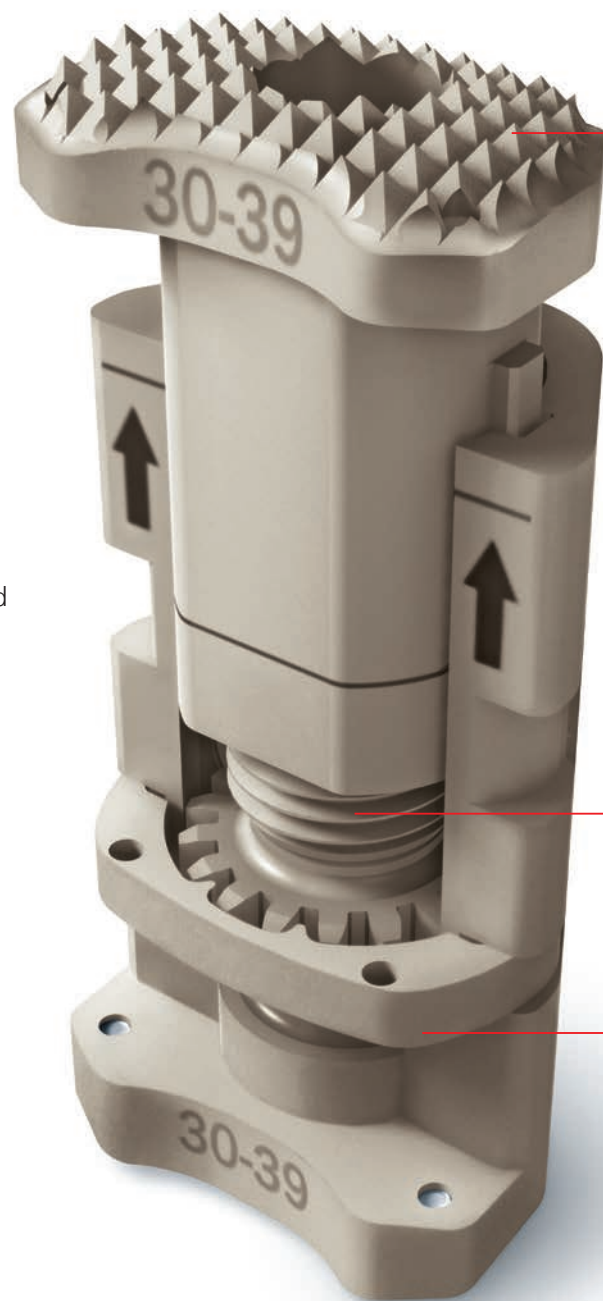
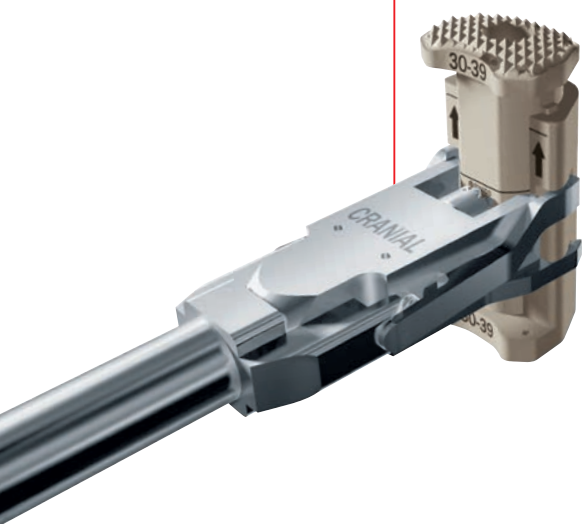

COMPATIBLE WITH PROVEN SYNTHES PRODUCTS

Anatomical shaped endplates

Cervical Retractor System enables a clear layout of the operative field



Vectra/Vectra-T for dynamic anterior fixation



Vectra



Vectra-T

Continuous expansion mechanism, expandable in situ

Electric/Air Pen Drive facilitates bone removal



Cervical Spine Locking Plates (CSLP) for rigid anterior fixation



CSLP Classic

Locking clip, secures the expanded implant to prevent micro movements

Axon for posterior fixation



CSLP Narrow



CSLP Variable Angle

AO ASIF PRINCIPLES

AO ASIF Principles of internal fixation

In 1958 the AO ASIF (Association for the Study of Internal Fixation) formulated four basic principles¹, which have become the guidelines for internal fixation. They are

- Anatomical reduction
- Stable internal fixation
- Preservation of blood supply
- Early, active, pain-free mobilization

The fundamental aims of fracture treatment in the limbs and fusion of the spine are the same. A specific objective in the spine is returning as much function as possible to the injured neural elements.²

AO ASIF Principles as applied to the spine²

Anatomical reduction

Restoration of normal spinal alignment to improve the biomechanics of the spine.

Stable internal fixation

Stabilization of the spinal segment to promote bony fusion.

Preservation of blood supply

Creation of an optimal environment for fusion.

Early, pain-free mobilization

Minimization of damage to the spinal vasculature, dura, and neural elements, which may contribute to pain reduction and improved function for the patient.

¹ M.E. Müller, M. Allgöwer, R. Schneider, and R. Willenegger: AO Manual of Internal Fixation, 3rd Edition. Berlin; Springer-Verlag. 1991.

² M. Aebi, J.S. Thalgott, and J.K. Webb. AO ASIF Principles in Spine Surgery. Berlin; Springer-Verlag. 1998.

INDICATIONS AND CONTRAINDICATIONS

ECD is a vertebral body replacement for the stabilization of the cervical (C3 to C7) and upper thoracic (T1 to T2) spine.

Depending on anatomical and pathological requirements, ECD can be used in the replacement of one, two or three adjacent vertebral bodies.

Indications

- Primary or secondary tumours of the cervical or upper thoracic spine.

Note: Always combine ECD with an additional, stable internal anterior, posterior or a combined (anterior/posterior) fixation system to bear tensile forces as well as torsion, flexion and extension moments.

Contraindications

- Severe osteoporosis
- Reconstruction of more than three adjacent vertebral bodies

IMPLANTS/SET

IMPLANTS

ECD – Expandable Corpectomy Device, PEEK, sterile

- Various endplate angles and heights
- Overlapping sizes
- Radiolucent material (PEEK)

Art. No	Height	Angle
891.300S	17–22 mm	4.5°
891.301S	20–27 mm	4.5°
891.302S	24–33 mm	6°
891.303S	30–39 mm	6°
891.304S	36–47 mm	7°
891.305S	43–59 mm	7°
891.306S	54–70 mm	7°

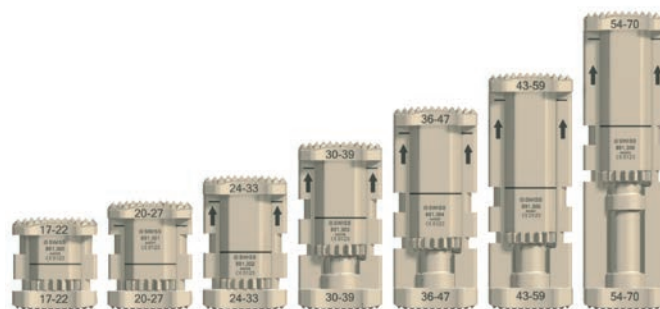

ECD Locking Clip, PEEK, sterile

- Secures the expanded implant to prevent micro movements

Art. No.
890.005S

ECD Locking Clip



SET

687.005	Vario Case for ECD, with lid, without contents
---------	--

INSTRUMENTS

397.127 Holding and Distraction Instrument, for ECD



397.129 Holder for ECD Locking Clip



324.060 Calliper for Corpectomy, short

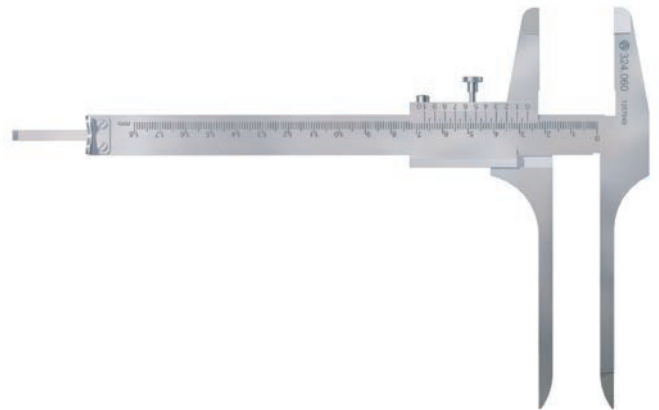

X000012 X-Ray Template for ECD in PEEK

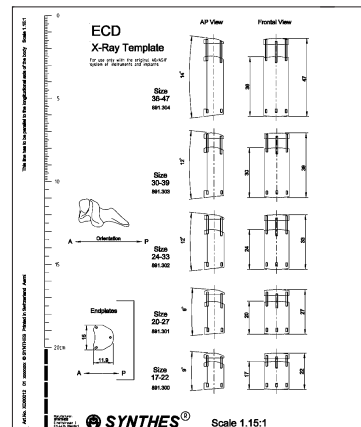

PREOPERATIVE PLANNING

1

Estimate implant height

Required instrument

X000012 X-Ray Template for ECD in PEEK

The X-Ray Template may be used to estimate the implant height. Place the template on the AP or lateral X-ray of the vertebrae to be bridged. Use the adjacent endplates as measuring points. Select the appropriate implant.

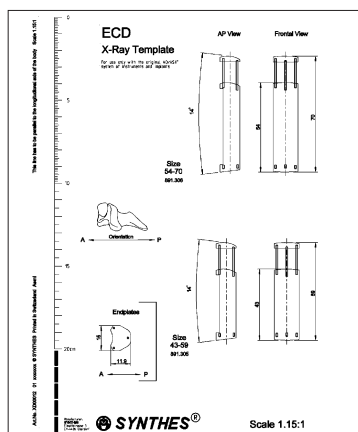
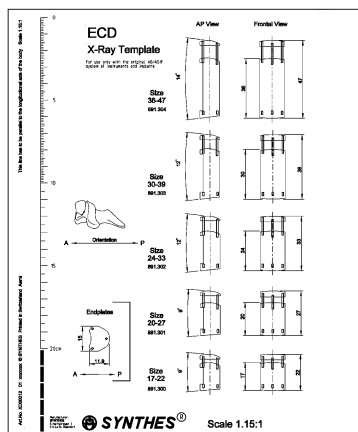

PATIENT POSITIONING AND APPROACH

1

Position the patient

Place the patient in a supine position.

- ① Proper positioning should be confirmed with a radiograph prior to draping.

Note: Physiological alignment cannot always be achieved. Always use caution when positioning the patient.

2

Approach

Recommended set

187.796	Cervical Retractors
---------	---------------------

Expose the vertebral bodies through a corresponding approach to the cervical spine.

To have a clear layout of the operative field the Synthes Cervical Retractor System can be used.

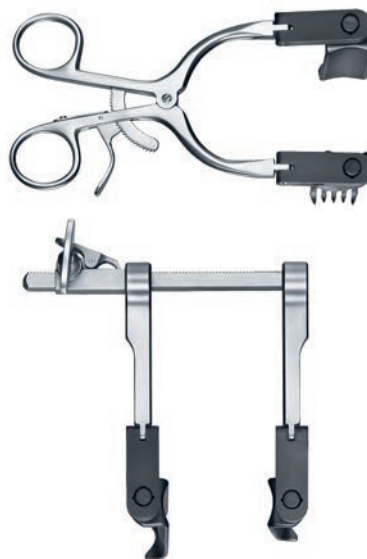

SURGICAL TECHNIQUE

1

Perform corpectomy and prepare endplates

Perform a partial or complete corpectomy as required by the pathology. Observe the following points:

Excise the disc material and the superficial layers of the cartilaginous parts of the adjacent endplates. Adequate cleaning of the endplate – especially in the peripheral parts – is important for the vascular supply. However, excessive tissue debridement and removal of dense bone may weaken the endplate and therefore impair the seating of ECD. In order to maintain the mechanical strength of the adjacent vertebral body endplates, avoid using chisels and resecting bony parts.



2

Distract segment

Distract segment to restore anatomical height.

3

Determine implant size

Required instrument

324.060	Calliper for Corpectomy
---------	-------------------------

Use the Calliper for Corpectomy to determine the size of the resulting spinal defect, taking the desired correction into account.

Determine the appropriate implant size. The height of the implant in its neutral position should be less than the height of the defect. The implant height when expanded should exceed the height of the defect, including the desired amount of anchorage.

Note: The optimal range of application for the implant is between its neutral position and 2/3 of its stroke.



4 Pick up implant

Required instrument

397.127	Holding and Distraction Instrument, for ECD
---------	--

Pick up the implant using the Holding and Distraction Instrument: Pull back the locking sleeve (1) (UNLOCK). Place the holding prongs into the notches of the implant (2). Release the locking sleeve. The force of the spring returns the mechanism to its original position so that the implant is securely attached to the instrument.

Note: When picking-up the implant, make sure that the cranially pointing arrows on the implant match the instrument side marked “CRANIAL”.

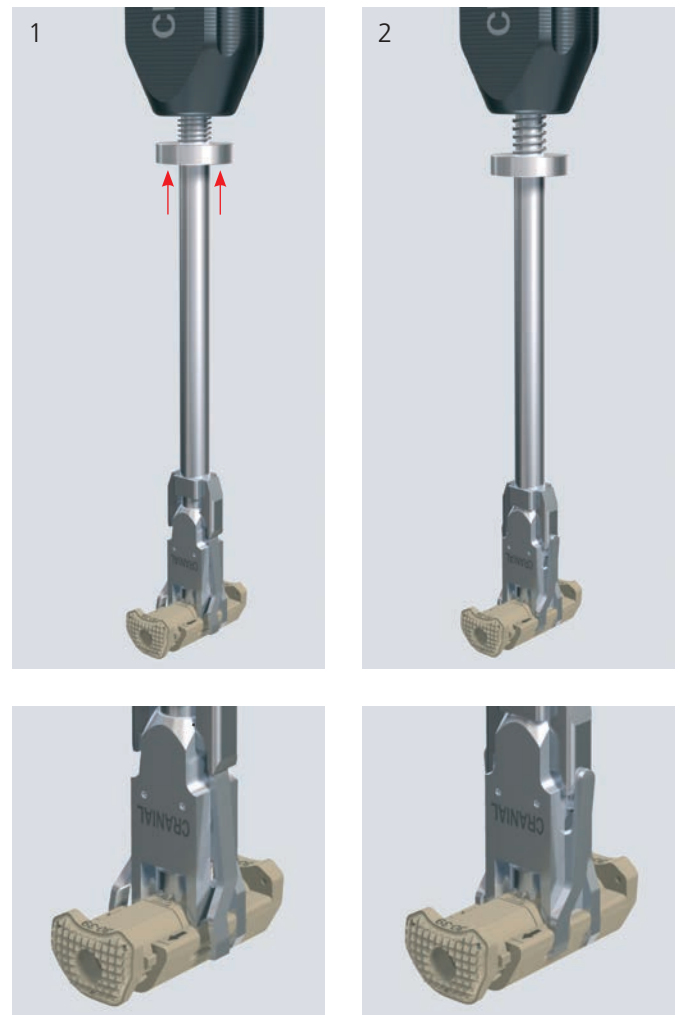

5

Implantation

Insert ECD into the resected part of the spinal column and align it in the sagittal and frontal plane.

The optimal position for ECD is in the centre of the vertebral endplate. To allow bony fusion, maintain some space around the implant endplates.



- Verify the position of ECD in relation to the vertebral bodies in the frontal and sagittal planes under the image intensifier. Three X-ray markers in each implant endplate serve to control the position of the PEEK implant.

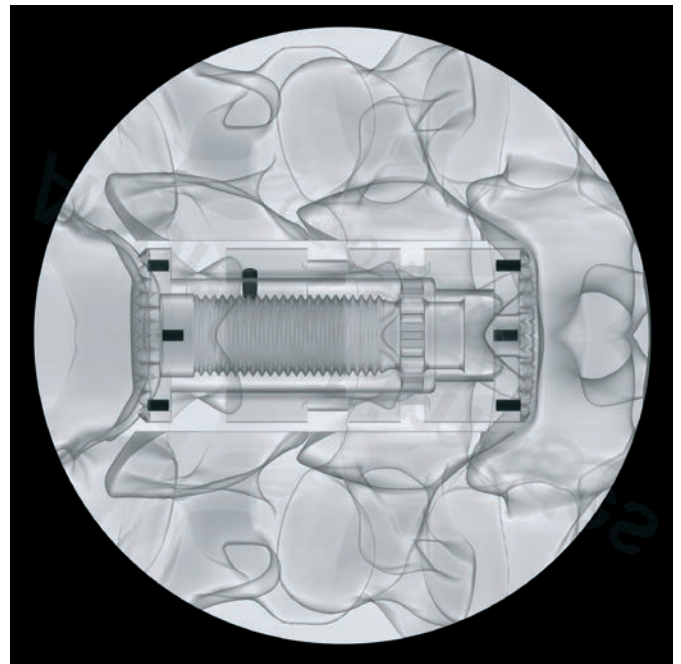

6 Expand implant

Required instrument

397.127	Holding and Distraction Instrument, for ECD
---------	---

Expand ECD in situ using the Holding and Distraction Instrument. Turn the rotary handle (1) in the direction indicated on the instrument (“expand”) until the desired height and anchorage is achieved.

Note: As soon as the implant endplates touch the vertebral endplates push the instrument slightly caudally in order to guarantee an optimal function of the expansion mechanism.

To release the implant, pull back the locking sleeve (UNLOCK) (2).

Important:

- A visual indicator (3) on the implant shows the maximum expansion position. Additional expansion, once this stroke limitation is reached may destroy the implant.
- Expansion must remain in the physiological range. Once the stroke limitation is reached, do not further expand. If the implant size is too small, remove the implant and replace it with a larger implant.

Verify the final position of ECD in relation to the vertebral bodies in the frontal and sagittal plane under the image intensifier.

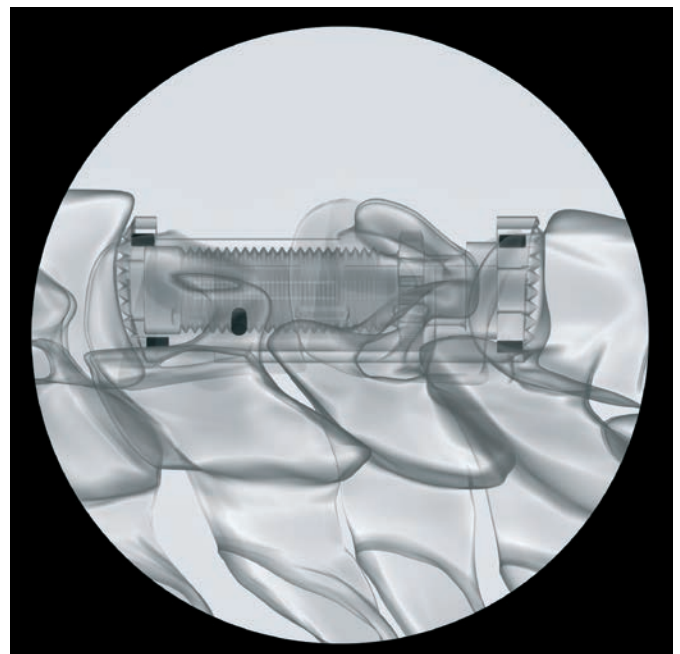
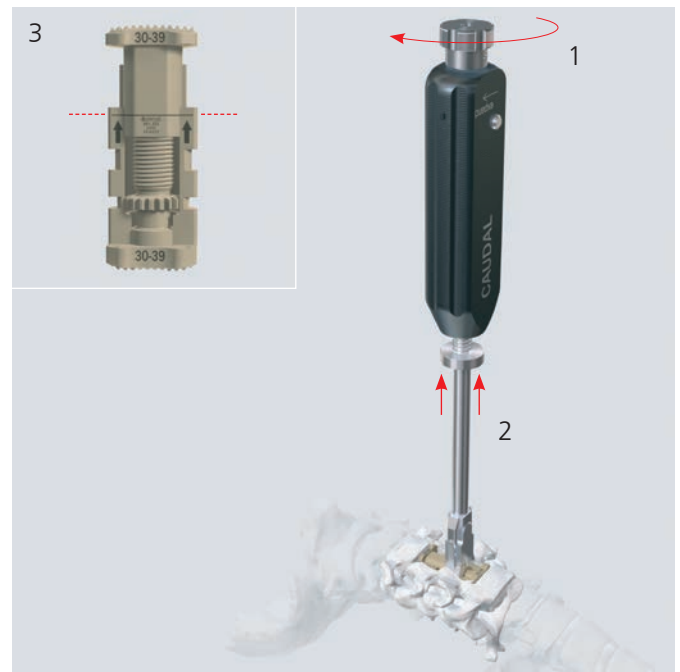

7

Secure implant with clip

Required instrument

397.129	Holding Instrument for Locking Clip ECD
---------	--

Place the pins of the Holding Instrument into the Locking Clip.

Insert the clip into the caudal notches of the implant.

Lift the instrument in a cranial direction to remove it from the clip.

Note: If necessary, the locking clip can be removed in the same way.

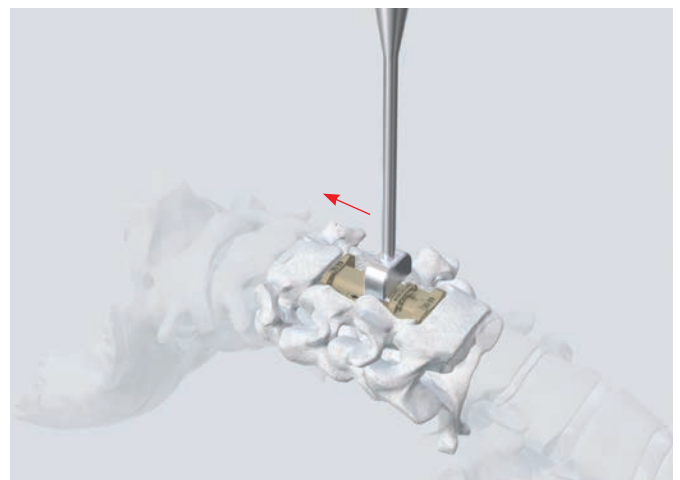
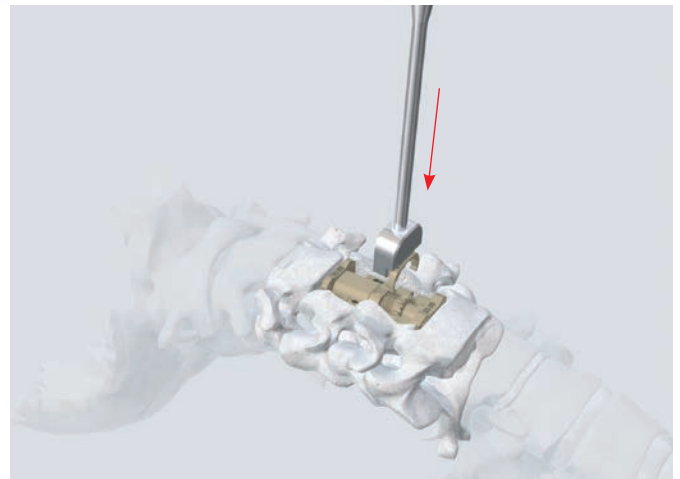
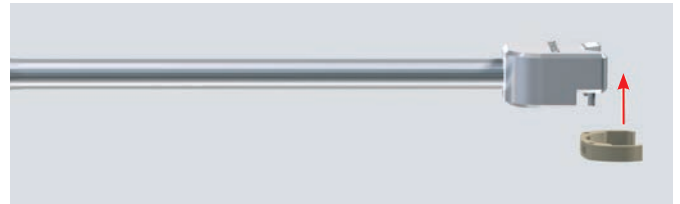

8

Add bone chips or chronOS

Fill the area around the ECD, especially the anterior part, with bone chips or chronOS*.



9

Additional fixation

Additional anterior, posterior or combined anterior/posterior fixation is necessary, e.g. with Vectra.



* See brochure "chronOS in Spine Surgery" (036.000.020).

